

ARM BM5 | SUSPENSION

TOUCH SCREEN SCALE

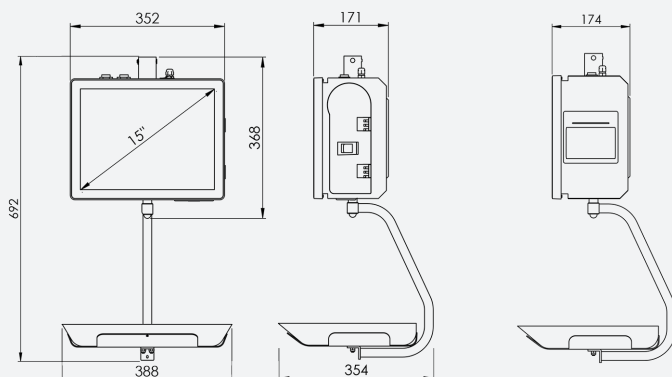

www.balancasmarqu.es



MANUFACTURED IN EUROPE

GRUPO JOSÉ PIMENTA MARQUES

ARM BM5 | SUSPENSION MODELS

TOUCH SCREEN SCALE

CHARACTERISTICS	MODEL	VERSION	REFERENCE
<ul style="list-style-type: none">· 15" TFT touch screen with Resistive technology.· 2nd Monitor 10.1" TFT.· Intuitive and user-friendly graphic interface.· Motherboard Marques i.MX6 2x1GHz (Dual CortexTM-A9 MPCoreTM).· Flash Disk 8GB eMMC.· Memory Ram 1GB DDR3-1333.· 2 USB ports.· 1 Ethernet port 10/100Mbps.· 58mm or 80mm thermal ticket printer with drop off paper refill.· Label model with the possibility of using 3 types of paper in the resident printer: continuous paper, labels and continuous self-adhesive paper.· Label model with sliding printing mechanism.· Stainless steel construction.· Italian plate: 330x287x50mm.· Software ETPOS certified by NMI Certin B.V. with No. TC8610, as part of a scale, in accordance with the requirements of EN 45501 and OIML R76-1, which ensures compliance with the essential requirements of Directive 2009/23/EC the non-automatic weighing instruments.	ARM Suspension 2 Printer 2" (58mm)	Range 15 kg Division 5 g	20384240712E
	ARM Suspension 3 Printer 3" (80mm)	Range 15 kg Division 5 g	20384250712E
	ARM Suspension Label Labeler	Range 15 kg Division 5 g	20384110712E

OPTIONS

· INTEGRATED 2D SCANNER	20730110000A
· RFID CARD READER	20738050000A
· WIFI	20741040000A
· ETPOS – LABELING MODULE	5D2301
· BMGEST	21207090000A



www.balancasmarques.com
facebook.com/balancasmarques

HEAD OFFICE

Edifício Balanças Marques
Parque Industrial de Celeirós, 2ª Fase
Apart. 2376
4701-905 Braga - PORTUGAL

LISBON SUPPORT CENTER

Rua Actriz Adelina Fernandes 15A Dto.
2795-005 Linda-a-Velha
Lisboa - PORTUGAL

T +351 253 309 830
F +351 253 672 882
email internacional@balancasmarques.pt